

TPM-3000

PS/2 Touch Pad Module



TPM-3000 TouchPad Module is a pointing device that includes two switches, left button and right button. It also features an emulated scroll wheel of a mouse. To move the cursor, the user can just lightly slide on the device surface by finger. Thanks to modularize mechanical design, it provides flexible product configuration and easy maintenance.

SPECIFICATION

Interface	PS/2	
Resolution	300 dpi	
Buttons / scroll wheel	Left Button and Right Button / support emulation of the scroll wheel	
Operating Voltage / Current	5V +/- 0.3 / 3.4mA	
Voltage Fluctuation	<= 100mA	
Voltage Rise Time	<= 1ms	
Displacement Magnification	1.00 ~ 1.27	
The Fastest Speed	117 cm/s	
ESD	Contact: +/- 4KV; Non-contact: +/- 8KV	
Operating Temper.	5 to 50 degrees Celsius (5% to 65% RH, 25 degree Celsius)	
Storage Temper.	-10 to 60 degrees Celsius (5% to 90% RH, 25 degree Celsius)	
Sensor Area	65 +/- 0.2 (L) x 49 +/- 0.2 mm	
Module Dimension	76 (L) x 80 (W) x 8.85 (H) mm	
Weight	50 +/- 2g (with metal plate & plastic frame)	

DIMENSION

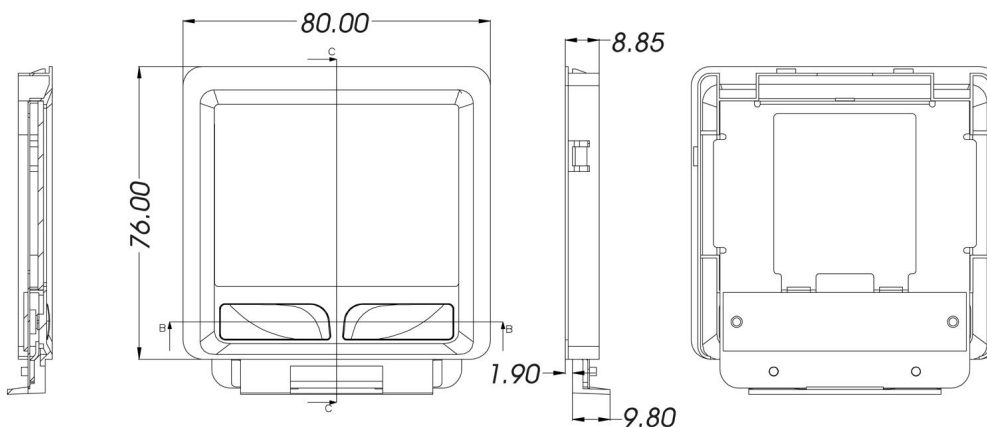

* Features and specification are subject to change without notice.